

Evaluation of the accuracy of a common regional registration method for three-dimensional reconstruction of edentulous jaw relation by a 7-axis three-dimensional measuring system

Yuchun Sun¹, Fusong Yuan¹, Hong Li, Yijiao Zhao, Peijun Lv and Yong Wang*
Peking University School of Stomatology Center of Digital Dentistry, Research Center of Engineering and Technology for Digital Dentistry, Ministry of Health and National Engineering Laboratory for Digital and material technology of stomatology, 22 Zhongguancun Nandajie, Haidian District, Beijing, P. R. China.

Abstract. This study was to design a method to quantitatively evaluate three-dimensional (3D) reconstruction accuracy of spatial relationship of dental models based on a 7-axis contact 3D measuring system, and to evaluate the accuracy of a common regional registration method for edentulous jaw relation reconstruction. 3D surface data of edentulous dental casts with 10 positioning cylinders and wax occlusion rims of five patients were obtained using a dental scanner. The jaw relation was reconstructed using the common regional registration in the Geomagic software. Measurements were obtained for line length, vertical distance and horizontal distance between centric points from two sources with upper jaw model base plane as a reference plane. The statistical description of measurement data was done. $\bar{x} \pm s$ of line length, vertical distance and horizontal distance between the center points of each data set were 0.107 ± 0.354 , 0.076 ± 0.576 and 0.108 ± 0.530 mm, respectively. Data was analyzed using the paired samples t-test and one-way analysis of variance. Paired t-test results of each patient and one-way analysis of variance for the five patients showed no significant differences ($P > 0.05$). Using the Faro Edge system and standardized positioning cylinders, quantitative evaluation of the 3D reconstruction accuracy of edentulous jaw relation was workable. And results of common regional registration method met clinical requirements.

Keywords: Edentulous jaw, jaw relation, three-dimensional scanning, three-dimensional reconstruction

1. Introduction

Obtaining 3D graphic data of the edentulous jaw alveolar ridge and jaw support with accurate jaw relation is a prerequisite for complete denture computer-aided design (CAD) [1-2]. Most 3D scanners of dental models tend to use the provided software registration method to reconstruct the jaw relation

*Corresponding author. E-mail: kqcadc@bjmu.edu.cn Phone: +86-10-62188981 Fax: +86-10-62142111

¹ These two authors contributed equally

of the upper and lower jaw model [3-6]. Some scanners based on dedicated positioning of mechanical jaw frame parameters will reset the scanned upper and lower jaw models to a spatial location consistent with the mechanical jaw frame [7-8]; however, the reconstruction accuracy of these scanners requires further evaluation.

This study intends to assess the ability of a common regional registration method to accurately reconstruct the upper and lower edentulous model jaw relation using a 7-axis 3D measuring system and to analyze the complete denture CAD/RP (rapid prototyping) source of error from the perspective of data acquisition.

2. Materials and methods

2.1. Experimental equipment and software

Computer hardware systems: Intel (R) Core (TM) i5-3550 processor, 8G memory, 1T hard drive and ViewSonic VG920 color display; 3D scanning system: Activity 880 (Smart Optics Corporation, Germany, accuracy of 0.02 mm); Scanning and design software: Geomagic Studio 2012 (Raindrop Corporation, USA), Imageware 11.0 (EDS Corporation, USA); Molding hardware: EnvisionTec digital wax-molding machine (EnvisionTec Corporation, Germany, layered accuracy of 0.025 mm); Measurement system: 7-axis Faro Edge contact measurement system with 3-mm zirconia ball i-probe (Faro Company, USA, accuracy of 0.024 mm); Statistical software: SPSS 13.3 (SPSS Inc., USA).

2.2. Experimental methods

2.2.1. Preparation of samples

Five completely edentulous patients from the Repair Department of Peking University Stomatological Hospital knowingly consented to be a part of this research study. Upper and lower edentulous jaws were cast with conventional elastic proofing cream and potassium alginate impression materials (two step impression method), then gypsum models were formed on pentagon-shaped standard model bases which are commonly used in the clinic. The wax denture was made in accordance with the requirements of a prosthodontics textbook by Feng and Xu published in 2005 [9]. The base plane of the bottom of the trimmed upper jaw gypsum model was created parallel to the occlusal plane.

2.2.2. Production of positioning cylinders

Imageware software was used to forward design the distal face of the standard positioning cylinders, and twenty identical standard positioning cylinders were manufactured with 3D resin using the EnvisionTec printer. The height, inner diameter and outer diameter of the cylinders were set at 5 mm, 3 mm and 6 mm, respectively. The 3-mm inner core was selected to match and fit the 3-mm Faro Edge probe exactly for maintenance of accurate and repeatable measurements of each cylinder center point. Figures 1 and 2 show two positioning cylinders bonded to each of the five axial surfaces of the upper and lower jaw standard model bases.

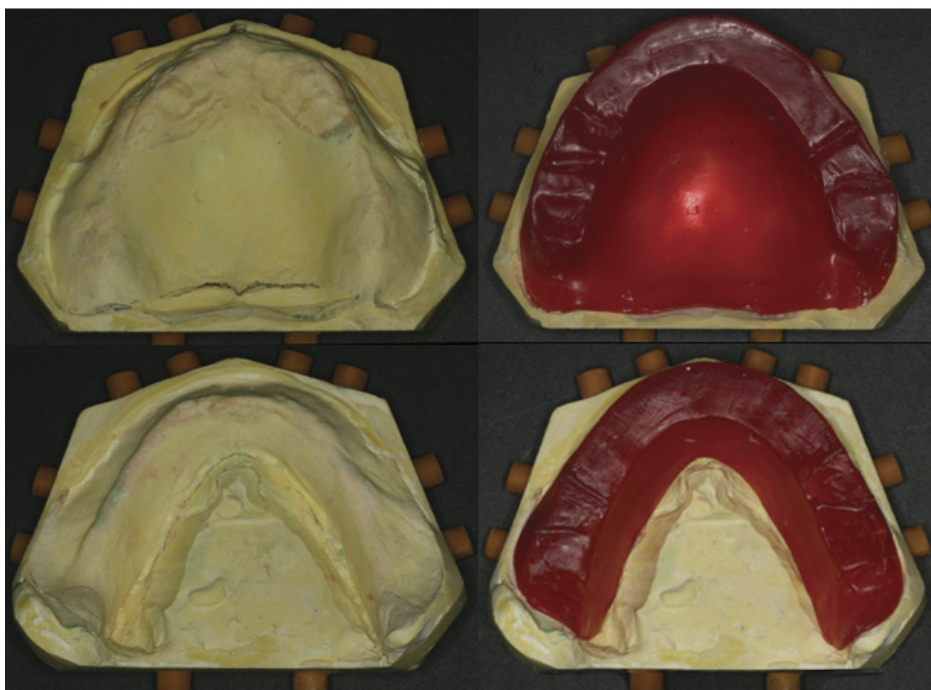

Fig. 1. Edentulous jaw model with installed positioning cylinders and occlusal surfaces of the wax denture

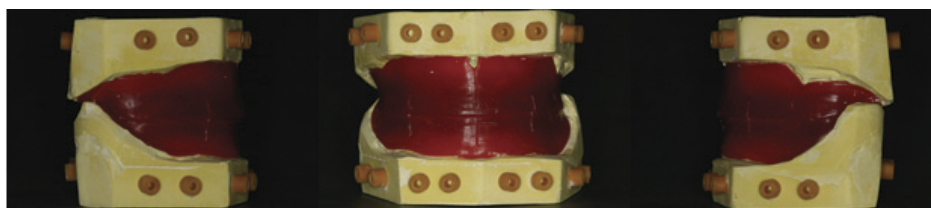

Fig. 2. Edentulous jaw model with installed positioning cylinders and the front and side surfaces of the wax denture

2.2.3. Reconstruction of jaw relation using 3D data acquisition and the common regional registration method

The wax denture in the upper and lower jaw gypsum model was correctly seated, then the denture surface was sprayed evenly with a special sunscreen (Yeti-Dental Company, Germany). Next, the upper and lower jaw gypsum model and denture were fixed in centric relation and installed in the Activity 800 scanner workspace where the entire lip and cheek surface was then scanned. This data set was saved in STL format and denoted as DATA1 (Figure 3). The upper and lower jaw gypsum model and the upper and lower wax denture were also scanned, and this data set was saved in STL format and denoted DATA2 (Figure 4). Data sets DATA1 and DATA2 were then imported into Geomagic 2012. Using the software's common area registration, we completed the coordinate system registration of DATA1 and DATA2 on the basis of DATA1. The registration process and results are shown in Figures 5 and 6, respectively.

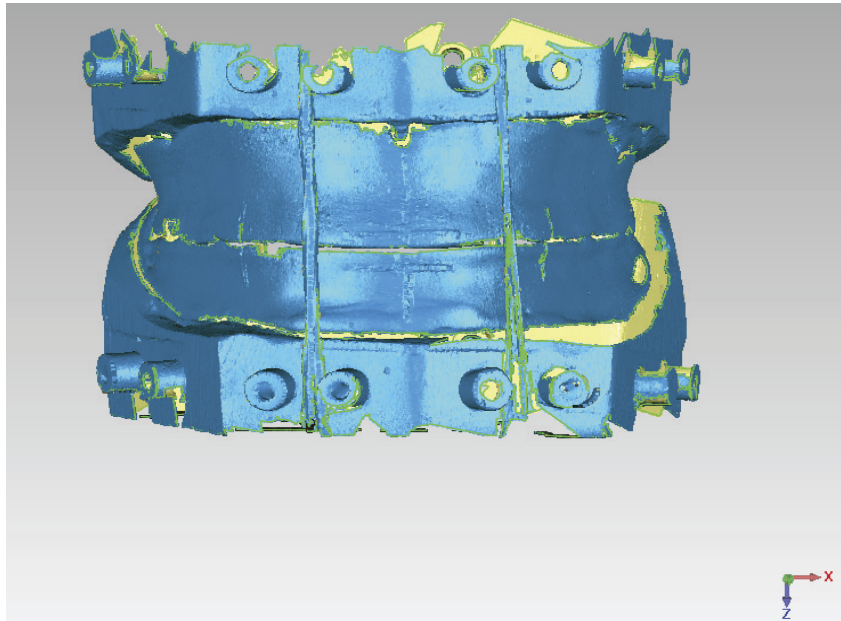

Fig. 3. Upper and lower jaw gypsum model and 3D scanned data (DATA1) of the denture lip buccal surface

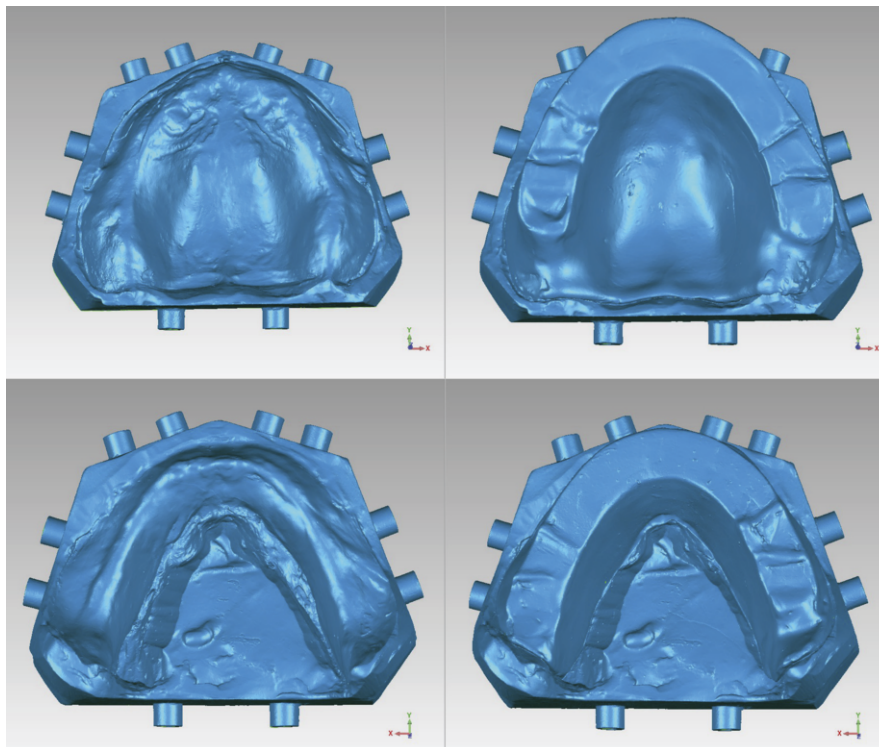

Fig. 4. 3D scanned data of the upper and lower jaw gypsum model (left) and wax denture (right) (DATA2)

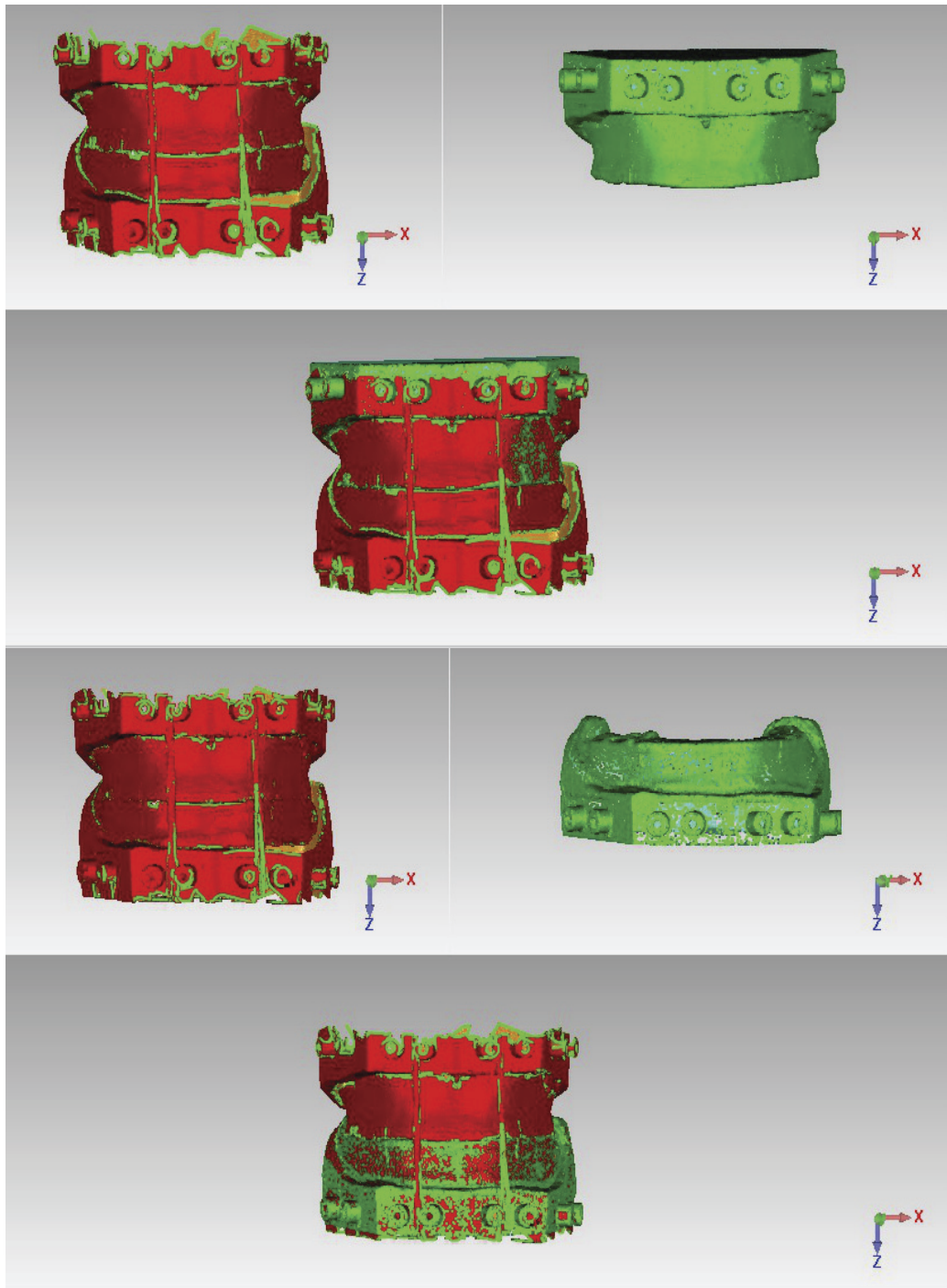

Fig. 5. Registration process of DATA1 and DATA2 in Geomagic

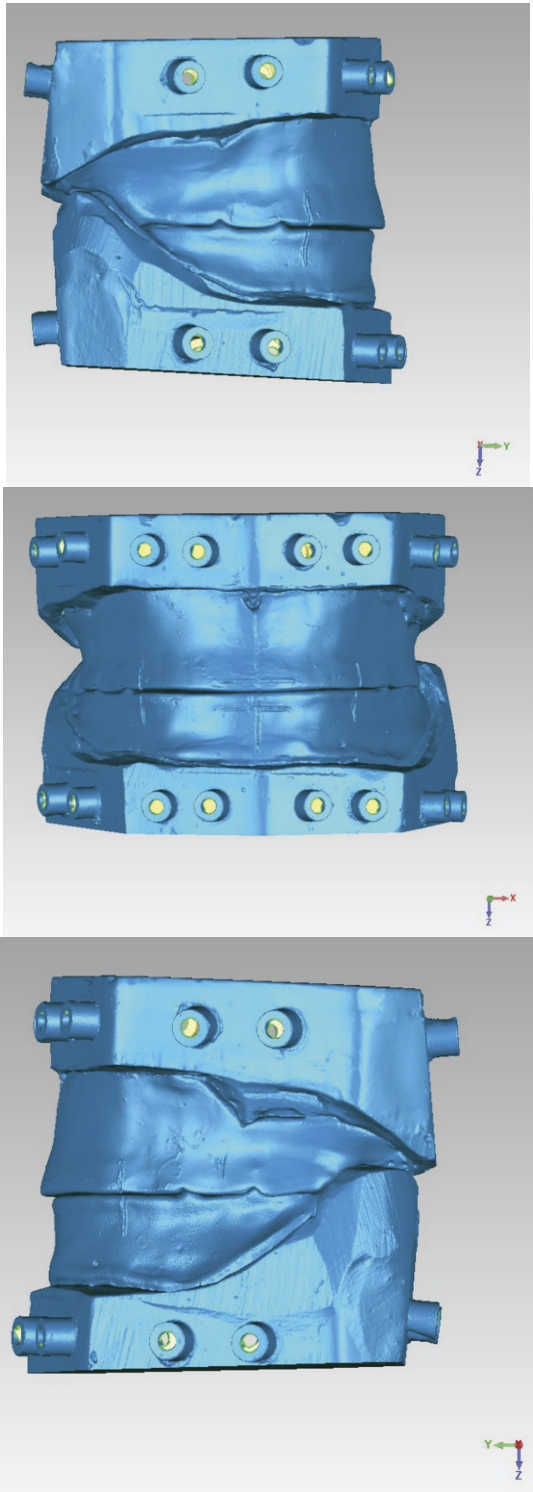

Fig. 6. Registration results of DATA1 and DATA2 in Geomagic

2.2.4. Paired measurements of distances between positioning cylinder distal face circle center points

The positioning cylinder distal face circle center points of the upper and lower jaw were divided into 12 groups or pairs of points that cross the plane of measurement. Each point was assigned a number and each group was given one of the following number-pair identifiers: 11-35, 12-35, 13-34, 14-33, 21-45, 22-45, 23-44, 24-43, 31-15, 32-15, 41-25 or 42-25. As noted, some points were used to make more than one measurement.

Using the Faro Edge 7-axis 3D measuring system, we measured and recorded base plane data from the bottom of the upper jaw gypsum model as well as the 20 positioning cylinder distal face circle center points of the upper and lower jaw gypsum model (Figure 7). Data was saved in the IGS file format and imported into the Imageware software where the center points were fitted using the software's center command. The line distance between the two points of every group was then measured (Figure 8). The Z coordinate absolute value of the center point of each group was regarded as the vertical distance. The center point along the Z-axis was projected into the measurement base plane, and the distance between points of projection of each group were calculated as the horizontal distance (Figure 9). All of the above measurements were repeated three times and we calculated the arithmetic mean value.

The 3D scanned data was imported into the Imageware software, and the base plane of the bottom of the upper jaw gypsum model was created parallel to the occlusal plane. The positioning cylinder's shaft surface and distal face plane were then fit in the program, allowing the outer diameter of the distal face to be determined. Lastly, using this outer diameter data, circle center points for the 20 cylinders were obtained with the software's center point command. (Figure 10) The line length, horizontal distance and vertical distance between center points of the 12 groups were measured as previously described.

Data from each of the five edentulous patients were obtained using this method, and measurement data was imported into SPSS 13.0 software for statistical analysis. Line length for each group from each model for two sources, the difference mean value of horizontal distance and vertical distance, standard deviation, and P values were determined by paired T-test analysis; the differences of measured data between 5 models were analyzed by one-way analysis of variance.

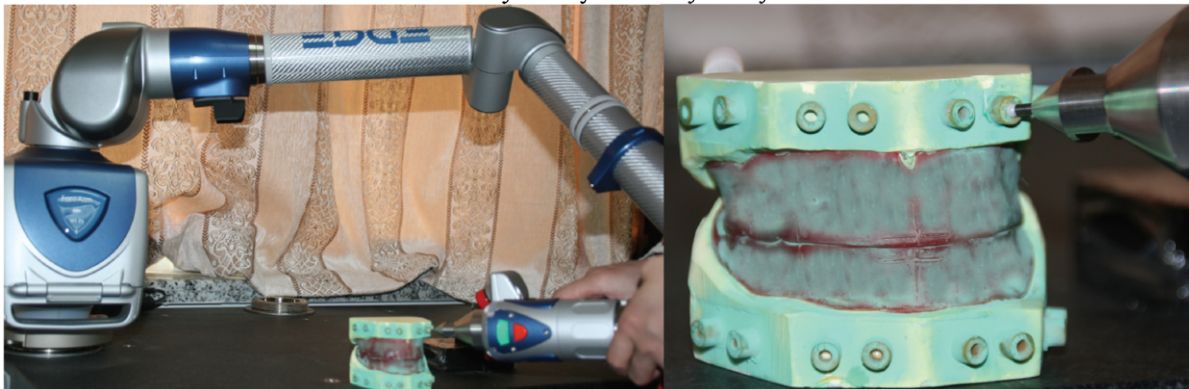

Fig. 7. Using the Faro Edge measurement system to record the distal face circle center points of positioning cylinders

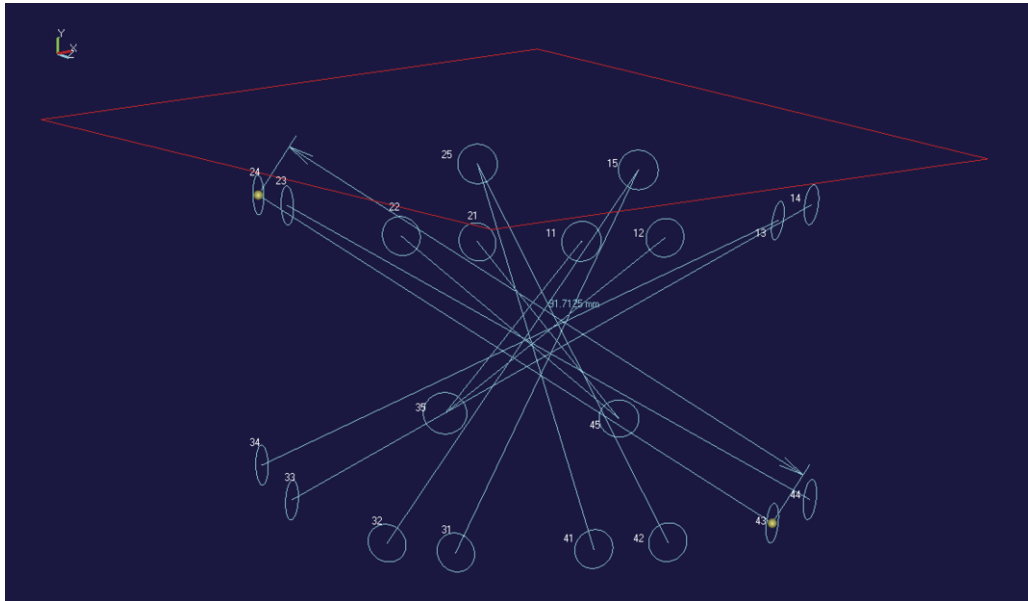

Fig. 8. Length of line segments between circle center points

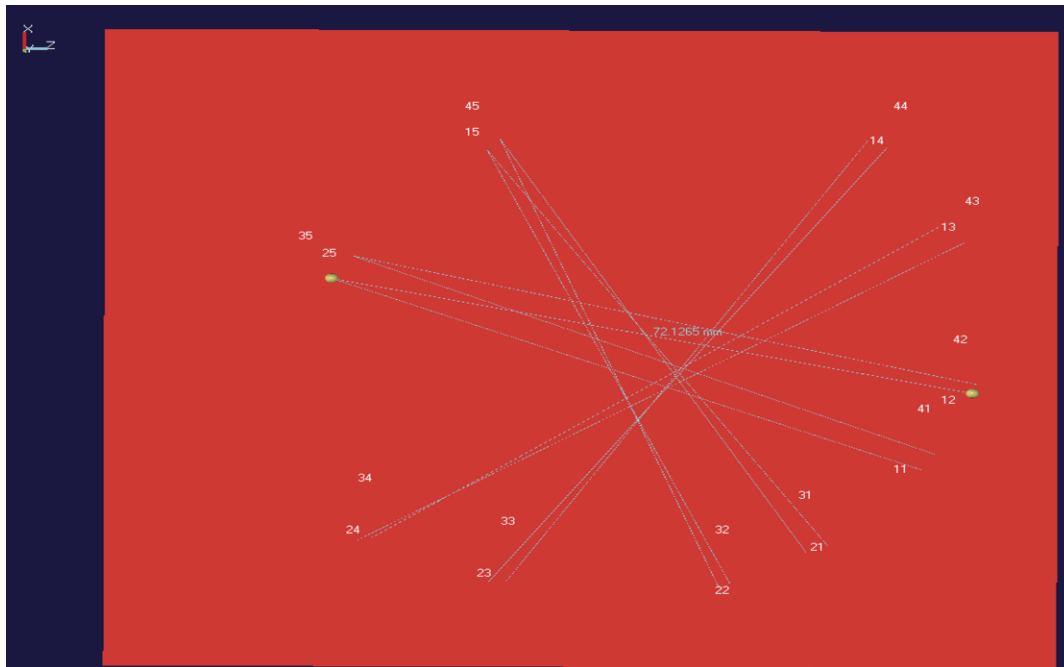

Figure 9. Horizontal distance between circle center points in the measurement base plane

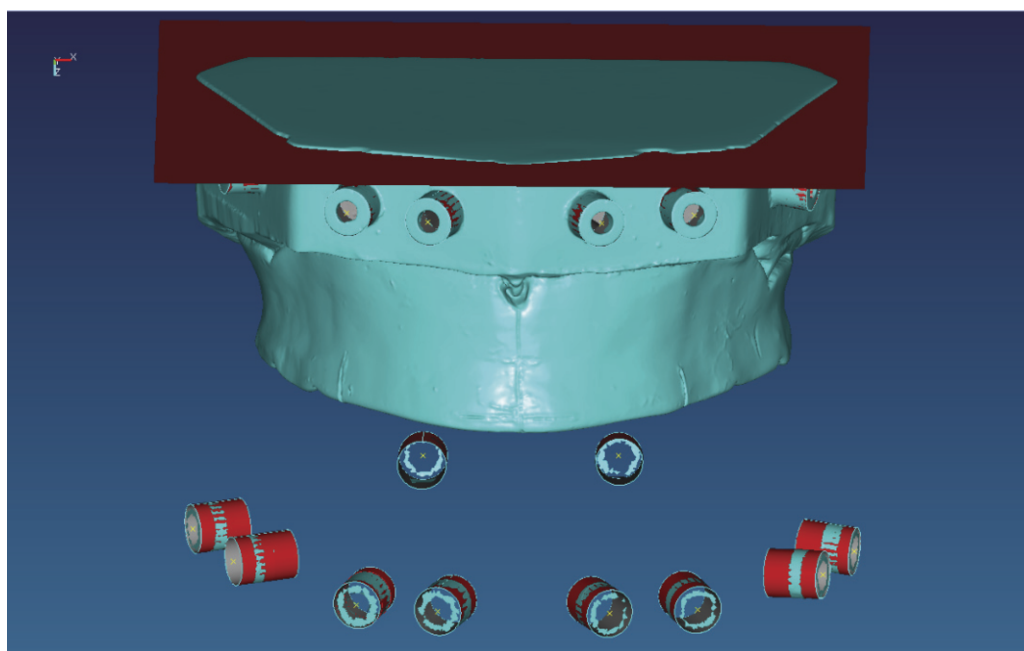

Fig. 10. Positioning cylinder distal face circle center points based on 3D scanned data

3. Results

3.1. Physical measurement

Measurement data of the line length, vertical distance and horizontal distance between the center points of each group for two sources of data from the five cases were collected, and data from patient 1 are shown in Table 1.

Table 1
Edentulous gypsum model measurement data from the Faro Edge measurement system and Smart Optics Activity 880 scanner (patient 1)

	Shortest Distance ¹ (mm)			Horizontal Distance ² (mm)			Vertical Distance ³ (mm)		
	Smart Optics	Faro	Difference	Smart Optics	Faro	Difference	Smart Optics	Faro	Difference
11-35	81.591	81.717	-0.126	68.535	68.296	0.239	47.116	47.030	0.086
12-35	82.917	83.065	-0.148	69.880	69.655	0.225	47.201	47.166	0.035
13-34	94.453	94.186	0.267	79.609	79.283	0.326	50.492	50.344	0.147
14-33	94.656	94.421	0.235	80.420	80.190	0.231	48.249	48.293	-0.043
21-45	81.357	81.275	0.083	68.037	67.676	0.361	47.999	47.727	0.272

22-45	82.433	82.259	0.174	69.172	68.553	0.619	48.173	48.161	0.012
23-44	90.210	90.409	-0.199	77.258	77.382	-0.123	48.185	48.073	0.112
24-44	90.722	90.766	-0.044	77.211	77.233	-0.022	48.001	47.931	0.070
31-15	87.178	87.223	-0.046	71.402	71.775	-0.373	46.347	46.597	-0.250
32-15	88.480	88.500	-0.019	72.821	73.141	-0.320	46.635	46.869	-0.233
41-25	85.674	85.559	0.115	70.033	70.383	-0.350	46.196	46.227	-0.031
42-25	86.216	86.082	0.133	70.661	70.991	-0.330	46.518	46.511	0.007

Distance¹: shortest distance in 3D space between the centers of two circles; distance²: horizontal distance between the centers of two circles; distance³: vertical distance between the centers of two circles

3.2. Statistical description

All measurement data of the line length, vertical distance and horizontal distance between the center points of each group for two sources of data were described statistically. The results were 0.107 ± 0.354 , 0.108 ± 0.530 and 0.076 ± 0.576 mm, respectively in Table 2.

3.3. Statistical analysis

Statistical analyses data are shown in Tables 2 and 3. The measured values of Faro Edge were used as the control group, and the measured values of common regional registration-reconstructed jaw relation were regarded as the experimental group. The difference values of the line lengths, vertical distance and horizontal distance between the center points of each group were calculated for their arithmetic means. The results of paired t-test analysis and one-way analysis of variance for these data were not significant ($P>0.05$).

Table 2
Results of the paired t-test analysis

	Shortest Distance ¹ (mm)		Horizontal Distance ² (mm)		Vertical Distance ³ (mm)	
	$\bar{x} \pm s$	P (two-tailed)	$\bar{x} \pm s$	P (two-tailed)	$\bar{x} \pm s$	P (two-tailed)
Patient 1	0.035±0.154	0.443	0.040±0.337	0.688	0.015±0.148	0.727
Patient 2	0.127±0.328	0.207	-0.019±0.675	0.924	0.108±0.554	0.514
Patient 3	0.141±0.681	0.490	0.035±0.684	0.862	0.160±0.683	0.436
Patient 4	0.113±0.300	0.220	0.250±0.637	0.201	0.139±0.834	0.577
Patient 5	0.119±0.308	0.208	0.070±0.545	0.664	0.120±0.433	0.358

Distance¹: shortest distance in 3D space between the centers of two circles; distance²: horizontal distance between the centers of two circles; distance³: vertical distance between the centers of two circles

Table 3-1

One-way analysis of variance (shortest distance in 3D space between the centers of two circles)

	Sum of squares	df	Mean squares	F	Sig.
Between groups	0.082	4	0.021	0.132	0.970
Within groups	8.579	55	0.156		
Total	8.661	59			

Table 3-2.

One-way analysis of variance (horizontal distance between the centers of two circles)

	Sum of squares	df	Mean squares	F	Sig.
Between groups	0.509	4	0.127	0.366	0.832
Within groups	19.145	55	0.348		
Total	19.654	59			

Table 3-3

One-way analysis of variance (vertical distance between the centers of two circles)

	Sum of squares	df	Mean squares	F	Sig.
Between groups	0.148	4	0.037	0.110	0.979
Within groups	18.461	55	0.336		
Total	18.608	59			

4. Discussion

Hardware and software systems for CAD and computer-aided manufacture (CAM) of full dentures are currently under development [10-14]. Indeed, prosthodontic modeling of complete dentition of a single jaw is already being assisted by 3D scanners. In this study, common regional registration technology was adopted to achieve a 3D reconstruction of spatial relationships of the upper and lower jaw gypsum model. However, the reconstruction accuracy of this type of software registration algorithm may be affected by the significant curvature and overall lack of geometric morphology of the edentulous alveolar ridge surface. Before this common regional registration method is further applied in denture CAD/CAM systems, its accuracy should be quantitatively evaluated.

The iterative closest point (ICP) algorithm is the core algorithm of software registration techniques such as common regional registration. The basic principle of this algorithm is iterative calculation of the distance between corresponding points of partially spatially overlapping groups of points. Through rigid transformation, the end result is the registration of spatial relationship with minimal alignment error. ICP registration techniques iteratively solve for the closest corresponding points, establish a

transformation matrix, implement transformation for one of the point groups until it reaches a certain convergence condition, and then iteration stops [15]. The basic requirement of the ICP algorithm is a minimal difference in the initial position of points. In the present study, the 3D registration model data is derived from multiple scanning operations. The differences in the distribution characteristics of constitution and the coordinate values of the corresponding point differences make ICP iterative calculation error difficult to avoid.

Previous studies tended to select anatomical landmarks or measured regions of an object as registration landmarks. As a result, the repositioning resolution of interactive selection points was poor. In this study, customized positioning cylinders standardized with an inner core diameter of 3-mm were used as markers. Imageware software was used to fit the center of the distal face of each cylinder, and the center points were measured directly using the Faro Edge system with a 3-mm zirconia probe. Measurement error was maintained within 10-40 μm .

Using this method, the line length, vertical distance and horizontal distance between the distal faces of cross positioned cylinders of the upper and lower jaw gypsum model were measured, and jaw relation of the edentulous jaw gypsum model as well as accuracy of 3D reconstruction of horizontal jaw relation were quantitatively evaluated. The common regional registration method resulted in mean errors of vertical and horizontal jaw relation measurements after 3D reconstruction of 0.108 mm and 0.2933 mm, respectively, which are less than the general error range of full denture jaw relation (0.5-1.0 mm) and meet clinical requirements [16]. Our research method is a simple 3D reconstruction method for edentulous gypsum model jaw relation which can be used to acquire full denture CAD/CAM 3D data.

In conclusion, using dedicated, standardized positioning cylinders, it was possible to both directly measure the length of a straight line between points in a complex physical model with a Faro 7-axis contact-type measurement system and quantitatively evaluate the accuracy of edentulous jaw model reconstruction using a common regional registration method. Future research should focus on achieving more accurate technical methods for reconstruction of the edentulous jaw relation model.

5. Acknowledgement

This study was supported by the National Natural Science Foundation of China (grant no. 81271181), the National High Technology Research and Development Program ("863" Program) of China (grant no. 2013AA040801), Beijing Nova Program (grant no. xxhz201301), Scientific Research Starting Foundation for the Returned Overseas Chinese Scholars, Peking University School and Hospital of Stomatology, Scientific Research Innovation Foundation for Youth Doctors of Peking University School of Stomatology (grant no. pkuss20110112)

References

- [1] Y. Sun, P. Lü and Y. Wang, Study on CAD&RP for removable complete denture, *Computer Methods and Programs in Biomedicine* 93 (2009), 266-272.
- [2] Y. Sun, P. Lü, Y. Wang, J. Han and J. Zhao, Research and development of computer aided design and rapid prototyping technology for complete denture, *Chinese Journal of Stomatology* 42 (2007), 324-329.1
- [3] K. Jensen and J. Sparring, Reconstructing teeth with bite information, *Image Analysis* 4522 (2007), 102-111.
- [4] G. Devico, L. Ottria, P. Bollero, M. Bonine, M. Cialone, A. Barlattani, and M. Gargari. Aesthetic and functionality in fixed prosthodontic: sperimental and clinical analysis of the CAD-CAM systematic 3Shape, *Oral & Implantology*, 1(3-4)(2008),104-115

- [5] G. Sannino, F. Gloria, R. Schiavetti, L. Ottria, and A. Barlattani. Dental Wings CAD/CAM system precision: an internal and marginal fit experimental analysis. *Oral & Implantology*, 2(3)(2009),11-20
- [6] Y. G. Chen, P. J. Lv, and Y. Wang. Evaluating the absolute marginal discrepancy of full crown with a digital method. *Stomatology* 31(6)2011, 321-323
- [7] S. Ayyildiz, C. Sahin, Ö. M. Akgün, and F. Basak. Combined Treatment with Laser Sintering and Zirconium: A Case Report of Dentinogenesis Imperfecta. *Case Reports in Dentistry*, 2013(2013),6
- [8] Y. Wang, Y. J. Zhao, P. J. Lv, and Z. K. Li. A scanning method for the dental casts of intercuspal position. *J. Peking University (Health Sciences)*.38(3)(2006).
- [9] H. Feng and J. Xu, *Prosthodontics*, Peking University Medical Press, Beijing, 2005.
- [10] P. Lü, Y. Wang, G. Li, Z. Zhang, Z. Zhao and Y. Zhang, Development of a system for robot aided teeth alignment of complete denture, *Zhonghua Kou Qiang Yi Xue Za Zhi* 36 (2) (2001), 139–142.
- [11] Y.-D. Zhang, Z.-F. Zhao, P.-J. Lu, Y. Wang, R.-J. Song and J.-L. Lu, Robotic system approach for complete denture manufacturing, *IEEE/ASME Transactions on Mechatronics*, 7 (3) (2002), 392–396.
- [12] P. Lü, Y. Wang, G. Li, Z. Zhang, Z. Zhao and Y. Zhang, A system of complete denture teeth composing with robot aid, *Chinese Journal of Dental Research*, 9 (2) (2006), 34–39.
- [13] Y. Maeda, M. Minoura, S. Tsutsumi, M. Okada and T. Nokubi, A CAD/CAM system for removable denture. Part I. Fabrication of complete dentures, *International Journal of Prosthodontics* 7 (1) (1994), 17–21.
- [14] M. Busch and B. Kordass, Concept and development of a computerized positioning of prosthetic teeth for complete dentures, *International Journal of Computerized Dentistry* 9 (2006), 113–120.
- [15] P.J. Besi and N.D. McKay, A method for registration of 3-d shapes, *IEEE Transactions on Pattern Analysis and Machine Intelligence* 14 (1992), 586-606.
- [16] Z. Huang, A simple method of improving the jaw relation of full denture, *Chinese Journal of Prosthodontics* 1 (2000), 202.